

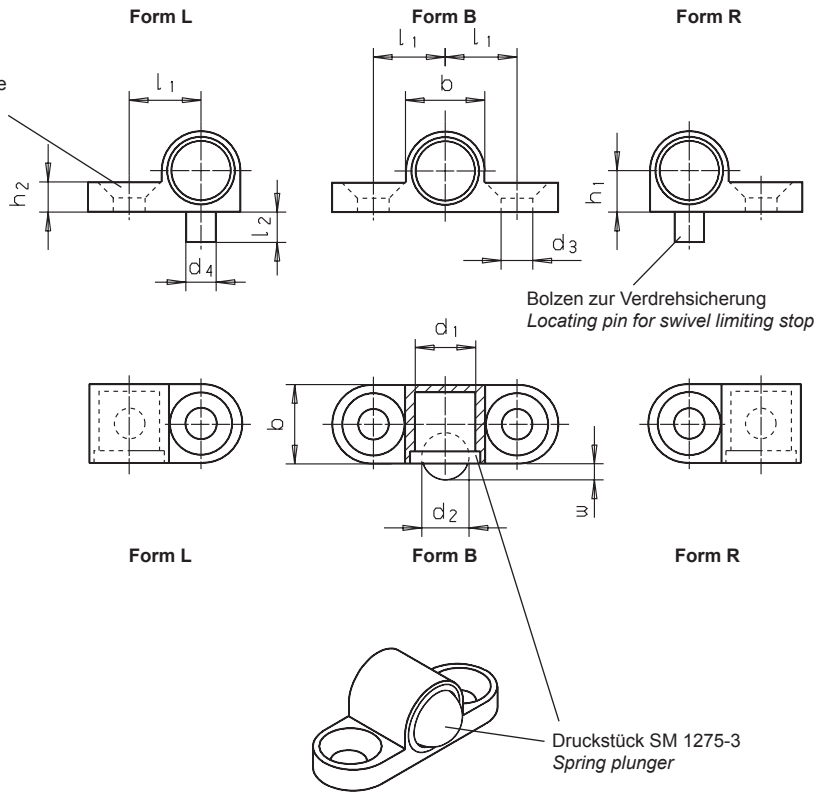

Bohrung für Senkschraube SM 1291-03  
Hole for countersunk screw



	<b>Catalog No.</b>	<b>Form</b>	<b>d<sub>1</sub></b>
	SM 1275-30	B	06

Zink-Druckguss, vernickelt  
zinc pressure die casting, nickel plated

mm

**Form B:** Befestigungsschraube beidseitig  
**Form L:** Befestigungsschraube links  
**Form R:** Befestigungsschraube rechts

Diese Druckstückhalter vereinfachen die Anwendung der Druckstücke SM 1275-3.

**Form B:** fixing screw both sides  
**Form L:** fixing screw left  
**Form R:** fixing screw right

These Holders simplify the use of spring plungers SM 1275-3.

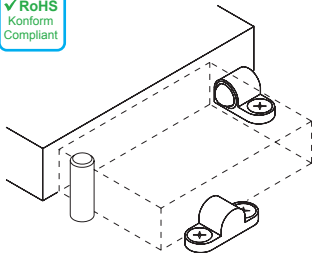

\* = statistischer Mittelwert / statistical average value

d <sub>1</sub> ∅ -0,05 für / for SM1275-3	d <sub>2</sub> ∅ Kugel ball	d <sub>3</sub> ∅ für / for SM1291-03	d <sub>4</sub> ∅ -0,05	b	h <sub>1</sub> ± 0,05	h <sub>2</sub>	l <sub>1</sub> ± 0,05	l <sub>2</sub>	Federkraft / spring load [N] ≈*	W -0,1 Federweg compression	kg 
06	5,0	3,2 M03	3	8,5	4,25	3,20	7,50	3,00	6,5 - 13,0	1,5	0,005
08	6,5	4,3 M04	4	10,5	5,25	4,20	9,50	4,00	8,0 - 18,0	1,8	0,005

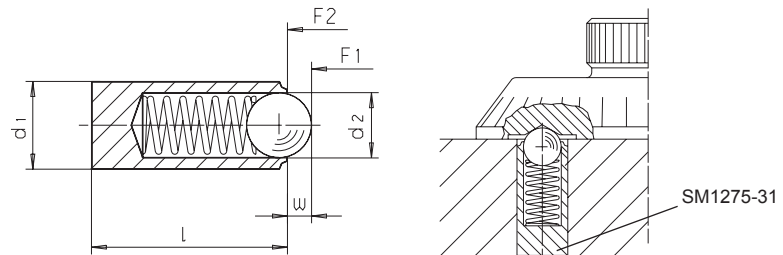

	<b>Catalog No.</b>	<b>d<sub>1</sub></b>
	SM 1275-31	03.0

Hülse: rostfreier Stahl 1.4305  
Kugel: rostfreier Stahl, gehärtet  
Feder: rostfreier Stahl

housing: stainless steel 1.4305  
ball: stainless steel, hardened  
spring: stainless steel

mm

Standard-Federkraft.  
Zur Arretierung sowie als An- und Abdruckstift.  
Temperatureinsatzbereich: max. + 250 °C.

Standard spring load.  
To be used for locating or for applying  
pressure or lifting off.  
Temperature range up to 250 °C.



\* = statistischer Mittelwert / statistical average value

d <sub>1</sub> ∅ ± 0,04	l	w	d <sub>2</sub> ∅	Druck / Pressure [N] ≈*		kg 
				F <sub>1</sub>	F <sub>2</sub>	
02.0	3,5	0,30	1,0	0,8	1,5	0,001
02.5	5,0	0,40	1,5	2,8	4,7	0,001
03.0	7,0	0,65	2,0	4,5	7,5	0,001
03.5	9,0	0,80	2,5	8,5	14,0	0,001
04.5	12,0	0,95	3,2	9,5	16,5	0,001
05.0	13,0	1,00	3,5	11,0	18,0	0,001
05.5	14,0	1,20	4,0	15,5	25,0	0,002
06.0	15,0	1,50	4,5	18,0	31,0	0,002
08.0	18,0	2,00	6,0	24,0	45,0	0,005
10.0	20,0	2,50	8,0	26,0	49,0	0,008
12.0	22,0	3,50	10,0	41,0	86,0	0,012

