



Form A



Form BKN



Form AKN



Form BN

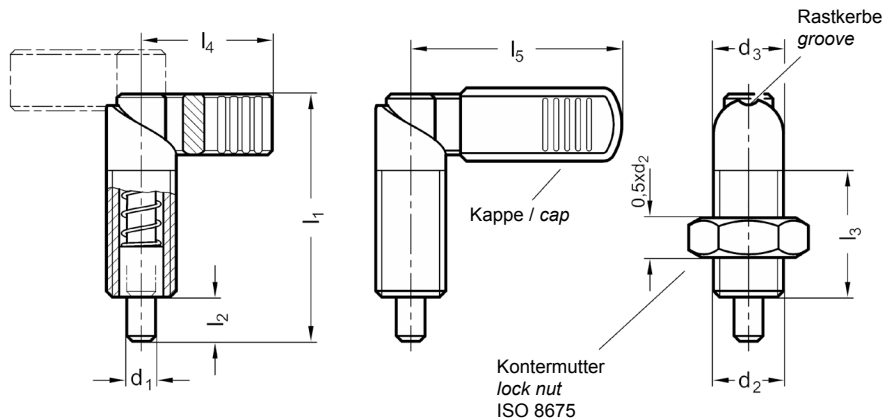

- Form A:** ohne Kontermutter, ohne PVC-Kappe / without lock nut, without PVC-cap
- Form AK:** mit Kontermutter, ohne PVC-Kappe / with lock nut, without PVC-cap
- Form AN:** ohne Kontermutter, ohne PVC-Kappe / without lock nut, without PVC-cap
- Form AKN:** mit Kontermutter, ohne PVC-Kappe / with lock nut, without PVC-cap
- Form B:** ohne Kontermutter, mit PVC-Kappe / without lock nut, with PVC-cap
- Form BK:** mit Kontermutter, mit PVC-Kappe / with lock nut, with PVC-cap
- Form BN:** ohne Kontermutter, mit PVC-Kappe / without lock nut, with PVC-cap
- Form BKN:** mit Kontermutter, mit PVC-Kappe / with lock nut, with PVC-cap



Catalog No.	Form	d ₁	d ₂
SM 1274	A	08	M20X1.5



- ST:** Stahl, brüniert
- Raststift:** geschliffen und nitriert
- NI:** Edelstahl rostfrei 1.4305 / 1.4404
- Raststift:** geschliffen und chemisch vernickelt
- Druckfeder:** Edelstahl rostfrei 1.4310
- Kappe:** Kunststoff (PA), schwarz matt
- ST:** steel, blackened
- plunger:** fine turned and nitrided
- NI:** stainless steel 1.4305 / 1.4404
- plunger:** fine turned and chemically nickel plated
- spring:** stainless steel 1.4310 / AISI 301
- cover:** Technopolymer (Polyamide PA) black, matt

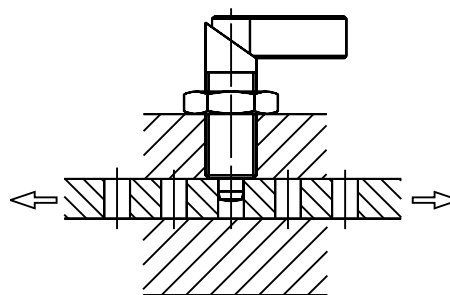

Rastriegel werden eingesetzt, wenn der Raststift zeitweise nicht vorstehen darf. Durch Drehen des Riegels um 180° wird der Raststift eingezogen und durch eine Rastkerbe in beiden Stellungen gehalten.
By rotating the lock through 180° the locking pin withdraws itself. A notch is provided in either position to prevent the lock from rotating.



mm



RoHS Konform Compliant

d ₁ ∅	d ₂ ∅		d ₃ ∅	l ₁	l ₂	l ₃ + 1,5	l ₄	l ₅	Federdruck Spring load [N] ≈		kg	
	Form A / AN / AK / AKN	Form B / BN / BK / BKN							Anfang initial	Ende end	Form A / B	Form AK / BK
04	M 10 x 1	-	10	37,5	6	19	21	-	7	20	0,015	0,020
05	M 10 x 1	-	10	37,5	6	19	21	-	7	20	0,017	0,020
05	M 12 x 1,5	M 12 x 1,5	12	47	8	26	26	32	8	18	0,028	0,037
06	M 10 x 1	-	10	37,5	6	19	21	-	7	20	0,030	0,038
06	M 12 x 1,5	M 12 x 1,5	12	47	8	26	26	32	8	18	0,030	0,038
06	M 16 x 1,5	M 16 x 1,5	16	56	10	30	32	42	11	29	0,060	0,063
08	M 12 x 1,5	M 12 x 1,5	12	47	8	26	26	32	8	18	0,035	0,039
08	M 16 x 1,5	M 16 x 1,5	16	56	10	30	32	42	11	29	0,061	0,064
08	M 20 x 1,5	M 20 x 1,5	20	69	12	36	37	52	21	57	0,122	0,156
10	M 16 x 1,5	M 16 x 1,5	16	56	10	30	32	42	11	29	0,070	0,083
10	M 20 x 1,5	M 20 x 1,5	20	69	12	36	37	52	21	57	0,124	0,160
12	M 20 x 1,5	M 20 x 1,5	20	69	12	36	37	52	21	57	0,126	0,163

* Bolzen / plunger -0,02/-0,05
Bohrung / bore H7

